



**QLSP13095YGH**  
(0603 0.95mm 35D Yellow-Green LED)



## Product Outline:

This is the much smaller than lead frame type components, thus enable smaller board size, higher packing density, reduced storage space and finally smaller equipment to be obtained.

## Features:

- Compatible with automatic placement equipment.
- Color: Yellow-Green
- RoHS compliant
- Compatible with infrared and vapor phase reflow solder process.
- Custom Bin available upon special request
- View angel typ. **35°**
- **0.95mm** Height

## Application:

- Backlighting in dashboard and switch.
- Telecommunication: indicator and backlighting in telephone and fax.
- Flat backlight for LCD, switch and symbol.
- General use.

## Compliance and Certification:



## Mechanical Property: (Dimension)

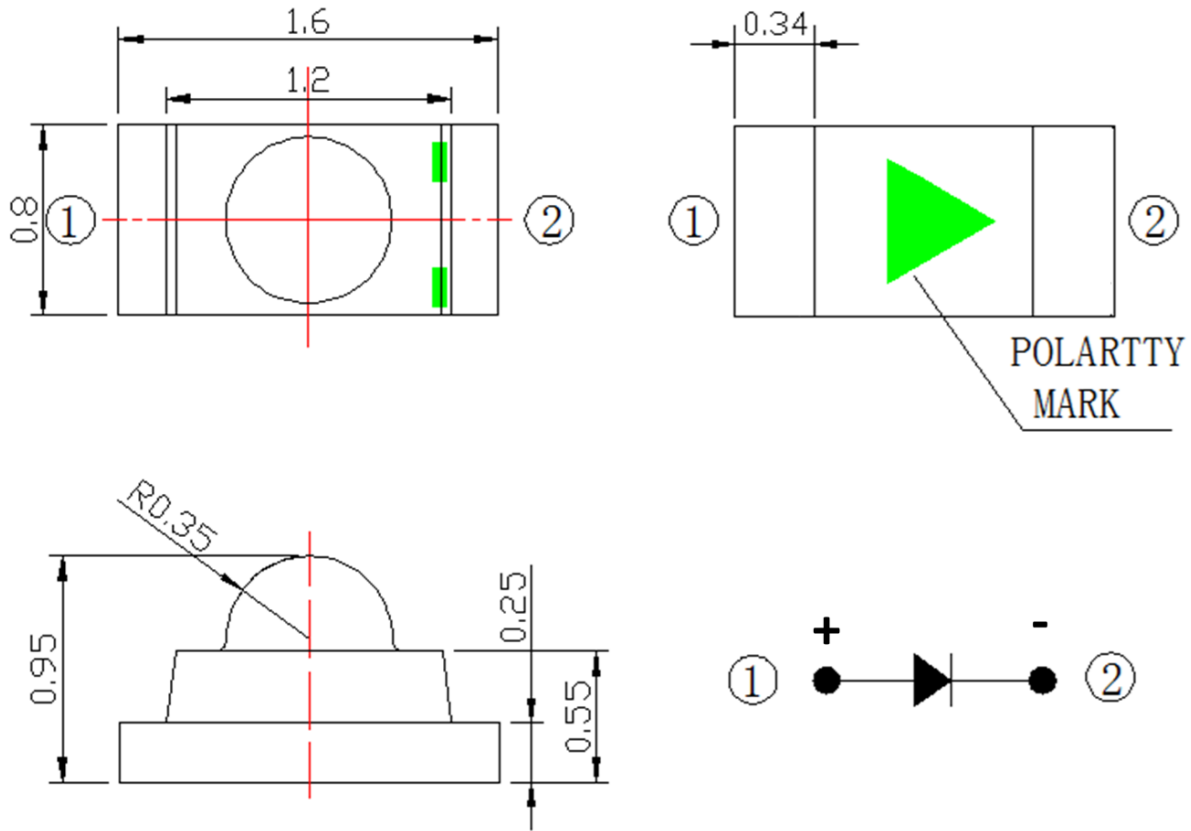

\* All dimensions are in millimeters,  
\* Tolerances are  $\pm 0.10\text{mm}$ .

## Recommended Solder footprint:

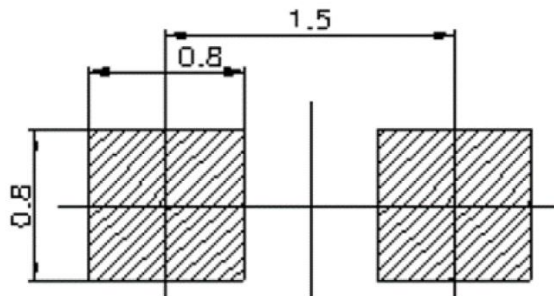

\* All dimensions are in millimeters.  
\* Reflow soldering must not be performed more than twice.



# Characteristics

## ■ Absolute Maximum Ratings

(Ta=25°C)

Parameter	Symbol	Rating	Unit
Reverse Voltage	$V_R$	5	V
DC Forward Current	$I_f$	25	mA
Pulse Forward Current (Duty 1/10 @1KHz)	$I_{FP}$	60	mA
Total Power Dissipation	$P_d$	55	mW
Storage Temperature	$T_{stg}$	-40 ~85	°C
Operation Temperature	$T_{opr}$	-40 ~ 85	°C
Soldering Temperature	$T_{sol}$	260 < 10 sec	°C

(1) Proper current rating must be observed to maintain junction temperature below maximum at all time

## ■ Electrical / Optical Characteristic

(Ta=25 oC)

Parameter	Symbol	Min.	Typ.	Max.	Unit	Condition
Luminous Intensity	$I_v$	100		250	mcd	$I_f=20mA$
Peak Wavelength	$\lambda_p$		570		nm	
Dominant Wavelength	$\lambda_d$	566		572	nm	
Forward Voltage	$V_f$	1.8		2.2	V	
View Angle	$\theta$		35		deg	

- (1). Tolerance of Luminous Intensity:  $\pm 11\%$   
 (2). Tolerance of Dominant Wavelength  $\pm 1nm$   
 (3). Tolerance of measurement:  $V_f = \pm 0.1V$



## Characteristic Curves

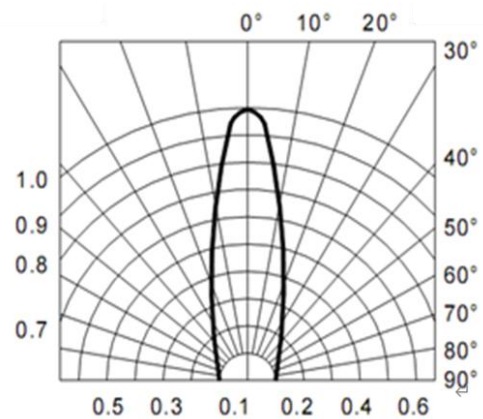
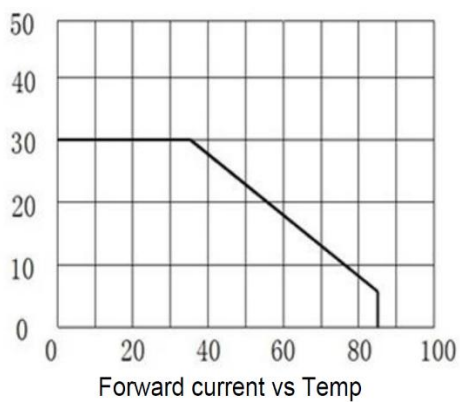
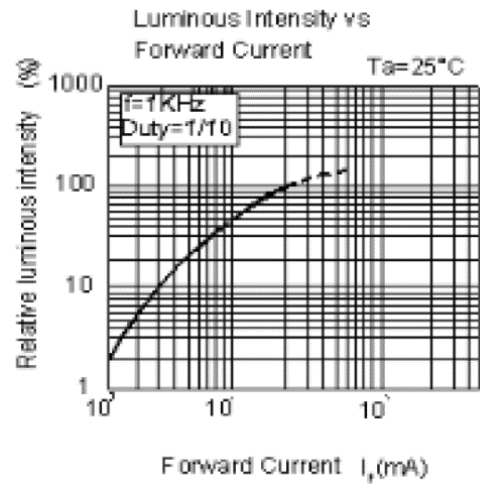
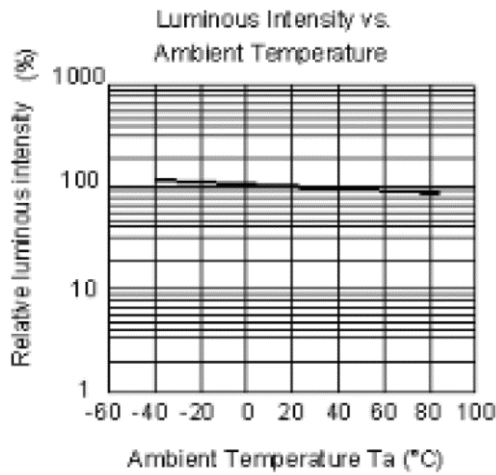
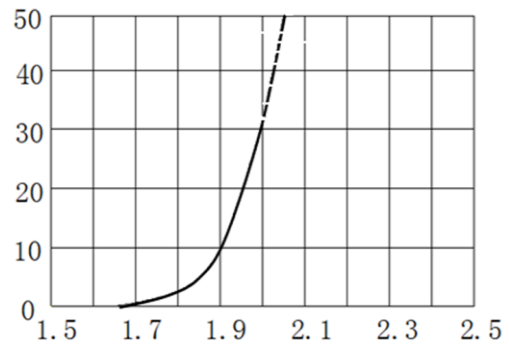
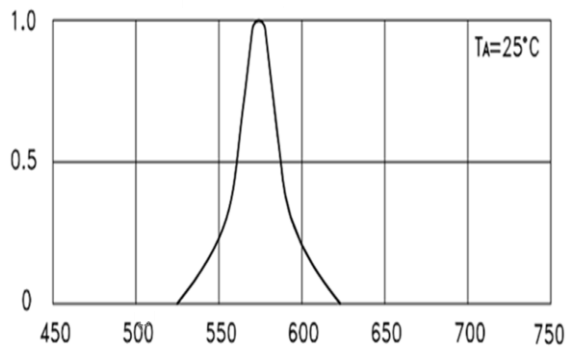

## ■ Reliability test:

No	Item	Condition	Time/Cycle	Sample size
1	Steady State Operating Life of Room Temperature	25°C Operating	1000 Hrs	20 pcs
2	Steady State Operating Life of Low Temperature -40°C	-40°C Operating	1000 Hrs	20 pcs
3	Steady State Operating Life of Low Temperature 60°C	60°C Operating	1000 Hrs	20 pcs
4	Steady State Operating Life of Low Temperature 85°C	85°C Operating	1000 Hrs	20 pcs
5	Low temperature storage -40°C	-40°C Storage	1000 Hrs	20 pcs
6	High temperature storage 100°C	100°C Storage	1000 Hrs	20 pcs
7	Steady State Operating Life of High Humidity Heat 60°C 90%	60°C/90% Operating	1000 Hrs	20 pcs
8	Steady State Pulse Operating Life Condition	25°C 10Hz duty=1/10 Operating	200 Cycle	20 pcs
9	Resistance to soldering heat on PCB (JEDEC MSL3)	pre-store@60°C, 60%RH for 52hrs Tslid max.=260 10sec	3 Times	20 pcs
10	Heat Cycle Test (JEDEC MRC)	25°C~65°C~-10°C, 90%RH, 24hr/1cycle	10 Cycle	20 pcs
11	Thermal shock	-40°C/ 20min~ 5min~100°C /20min	300 Cycle	20 pcs

## ■ Judgment Criteria:

Item	Symbol	Test Condition	Judgment Criteria
Forward Voltage	Vf	R : IF=20 mA	$\Delta V_f < 10\%$
Luminous Flux	Iv		$\Delta I_v < 30\%$



## Solder Profile:

-The recommended reflow soldering profile is as follows (temperatures indicated are as measured on the surface of the LED resin):

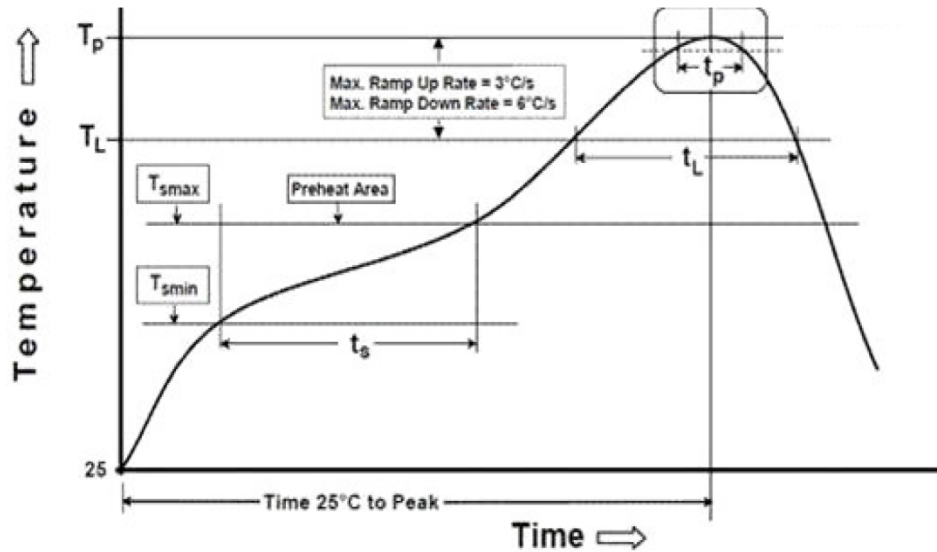

Profile Feature	Sn-Pb Eutectic Assembly	Pb-Free Assembly
Temperature Min( $T_{smin}$ )	100°C	150°C
Temperature Max( $T_{smax}$ )	150°C	200°C
Time( $t_a$ ) from ( $T_{smin}$ to $T_{smax}$ )	60-120 seconds	60-120 seconds
Ramp-up rate( $T_L$ to $T_p$ )	3°C/second max.	3°C/second max.
Liquidous Temperature( $T_L$ )	183°C	217°C
Time( $t_L$ ) maintained above $T_L$	60-150 seconds	60-150 seconds
Peak package body temperature( $T_p$ )	235°C	260°C
Time within 5°C of Actual Peak temperature ( $t_p$ )	20seconds*	30 seconds*
Ramp-down rate( $T_p$ to $T_L$ )	6°C/second max.	6°C/second max.
Time 25°C to peak temperature	6 minutes max.	8 minutes max.

\* Tolerance for peak profile temperature ( $T_p$ ) is defined as a supplier minimum and a user maximum.



## Taping & Packing:

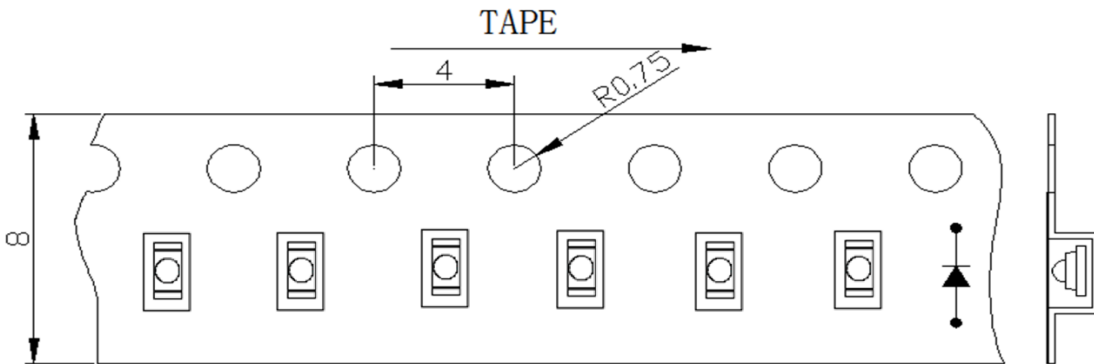

Unit : mm

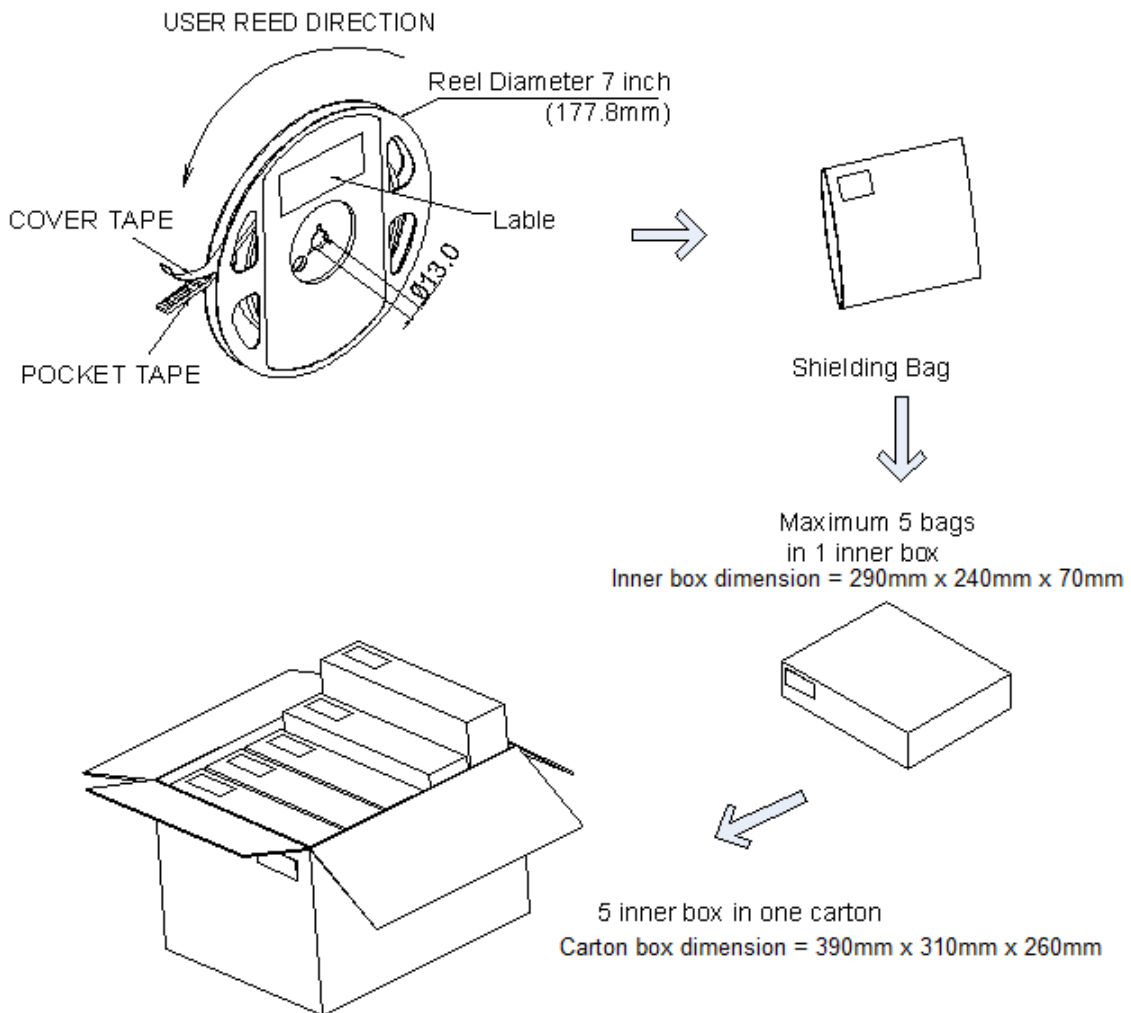

## Labeling

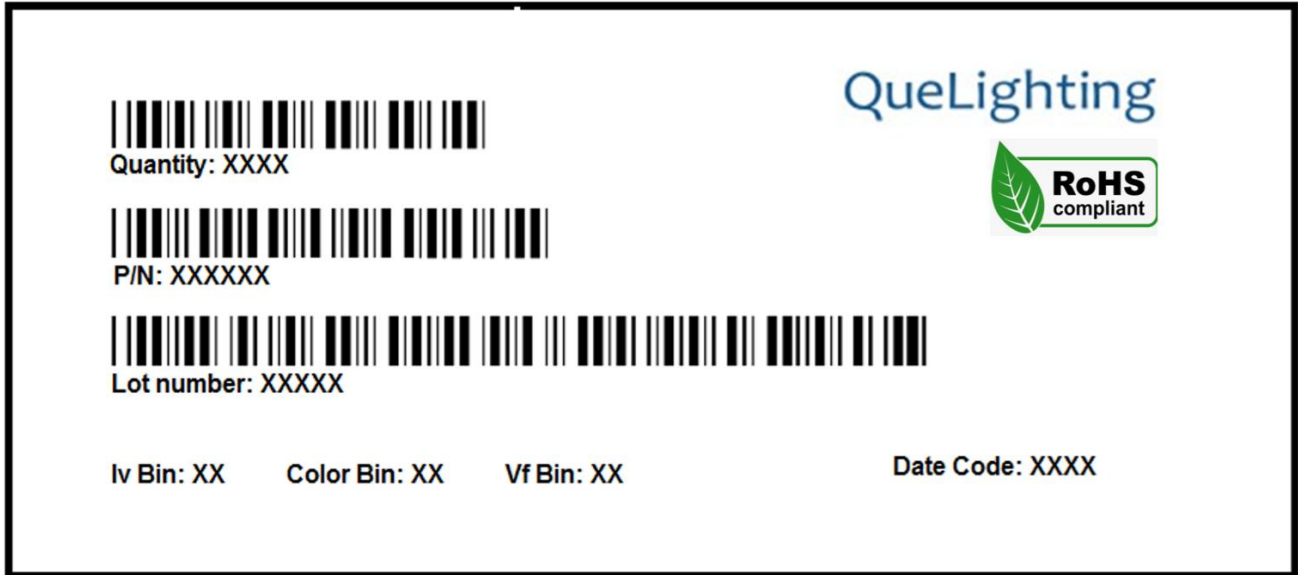

## Ordering Information:

Part #	Multiple Quantities	Quantity per Reel
QLSP13095YGH		3000 pcs



## Revision History:

Revision Date:	Changes:	Version #:
02-10-2026	Initial release	1.0

