



Q **QUELIGHTING**
Sustainable Lighting Solution



QLSP30WXK
(4040 side view)



Product Outline:

QLSP30WXK series are white LEDs bring high performance and quality of light to wide range of lighting application. The lighting application such as cation light, decoration light, signal, specific industrial and commercial lighting.

Features:

- High brightness output @ 60mA
- Package Dimension = 3.95mmX4.0mmX3.55mm
- ESD protection up to 4KV
- RoHS compliant
- Custom Bin available upon special request

Application:

- Daytime Running Light
- Architecture Lighting
- Garden Lighting
- Indoor Lighting
- Outdoor Lighting

Compliance and Certification:



Mechanical Property: (Dimension)

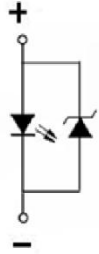
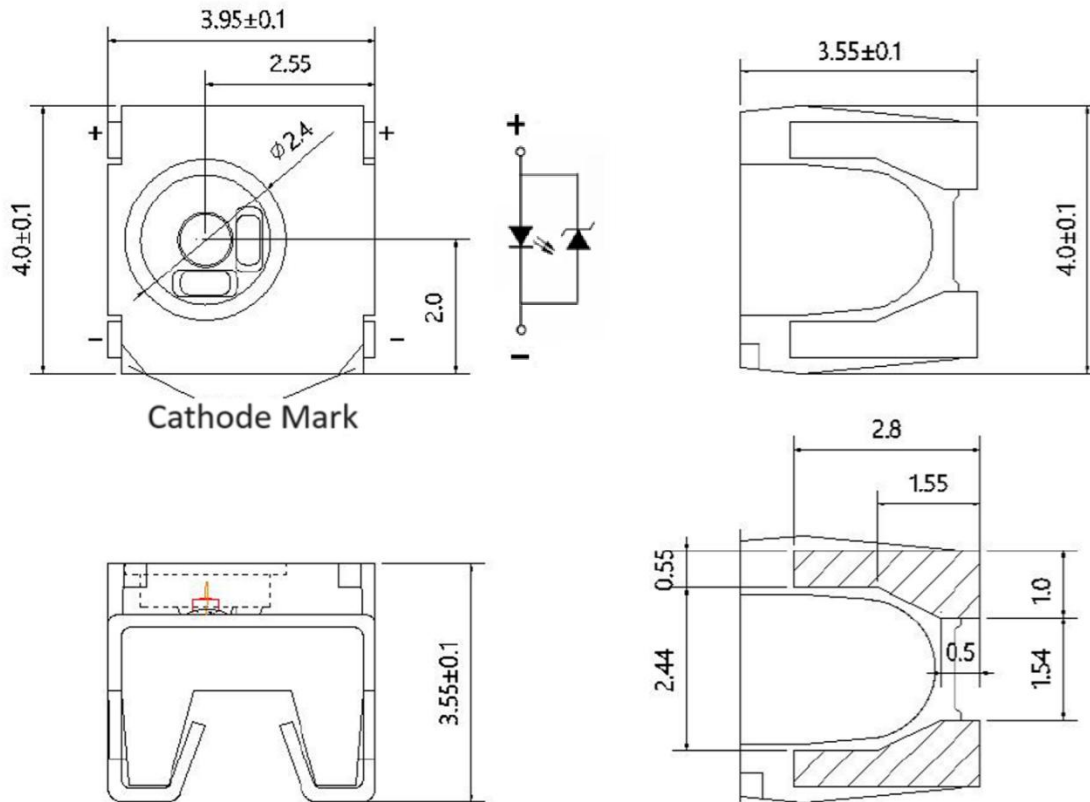

Tolerance: $\pm 0.1 \text{ mm}$

tolerances are $\pm 0.10 \text{ mm}$.

Recommended Solder footprint:

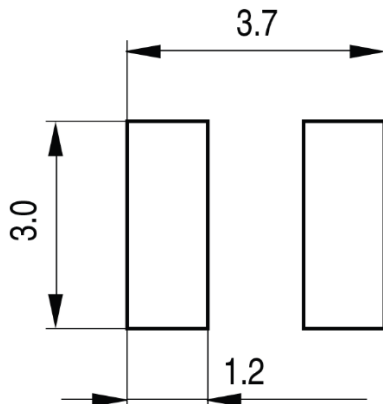

* All dimensions are in millimeters.

* The LEDs is designed to be reflow soldered on to a PCB. IF dip soldered that QL cannot guarantee its reliability.

* Reflow soldering must not be performed more than twice.



Electrical / Optical Characteristic

(T=25°C)

Product	Color	I _F (mA)	V _F (V)		CCT K	Luminous Flux (lm)	
			Typ.	max		Min	typ.
QLSP30PCAK	PC Amber	60	3.2	3.4	1600K	14	16
QLSP30WCWK	Candle White	60	3.2	3.4	2100K	14	16
QLSP30WW1K	Warm White	60	3.2	3.4	2700K	18	20
QLSP30WW2K	Warm White	60	3.2	3.4	3000K	18	20
QLSP30WNK	Neutral White	60	3.2	3.4	4000K	18	22
QLSP30WPK	Pure White	60	3.2	3.4	5000K	18	22
QLSP30WC2K	Cold White	60	3.2	3.4	6500K	18	22

*Tolerance = +/- 10%

Absolute Maximum Rating

(T=25°C)

Part #	P _d (mW)	I _F (mA)	I _{FP} (mA)*	V _R (V)	T _J (°C)	TOP (°C)	T _{ST} (°C)	T _{SOL} (°C)**	R _{th(J-S)} (C/W)***
QLSP30WXK	200	60	90	5	120	-40 – 80	-40 – 85	260	30

*Duty 1/10 @ 10Khz

** IR Reflow for no more than 10 sec @ 260 °C

*** Junction to substrate



White Binning

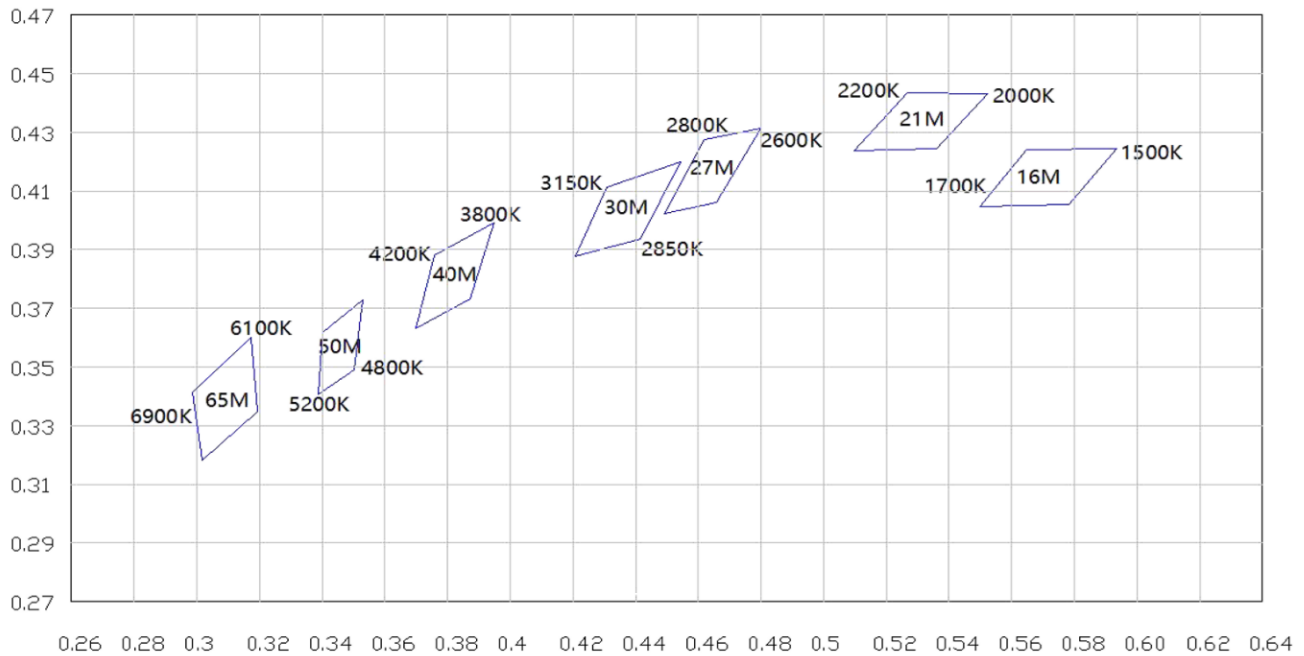

Forward Voltage (VF) Bin:

VF Rank (V)			
Color	Code name	Low	High
White	01	2.8	3.0
	23	3.0	3.2
	45	3.2	3.4
	67	3.4	3.6

The forward voltage tolerance is $\pm 0.1V$

Luminous Flux Bin:

Rank @ 60mA (lm)			
Color	Code name	Low	High
White	QGH	14	18
	QIK	18	24

luminous flux tolerance is $\pm 7\%$



Characteristic Curves

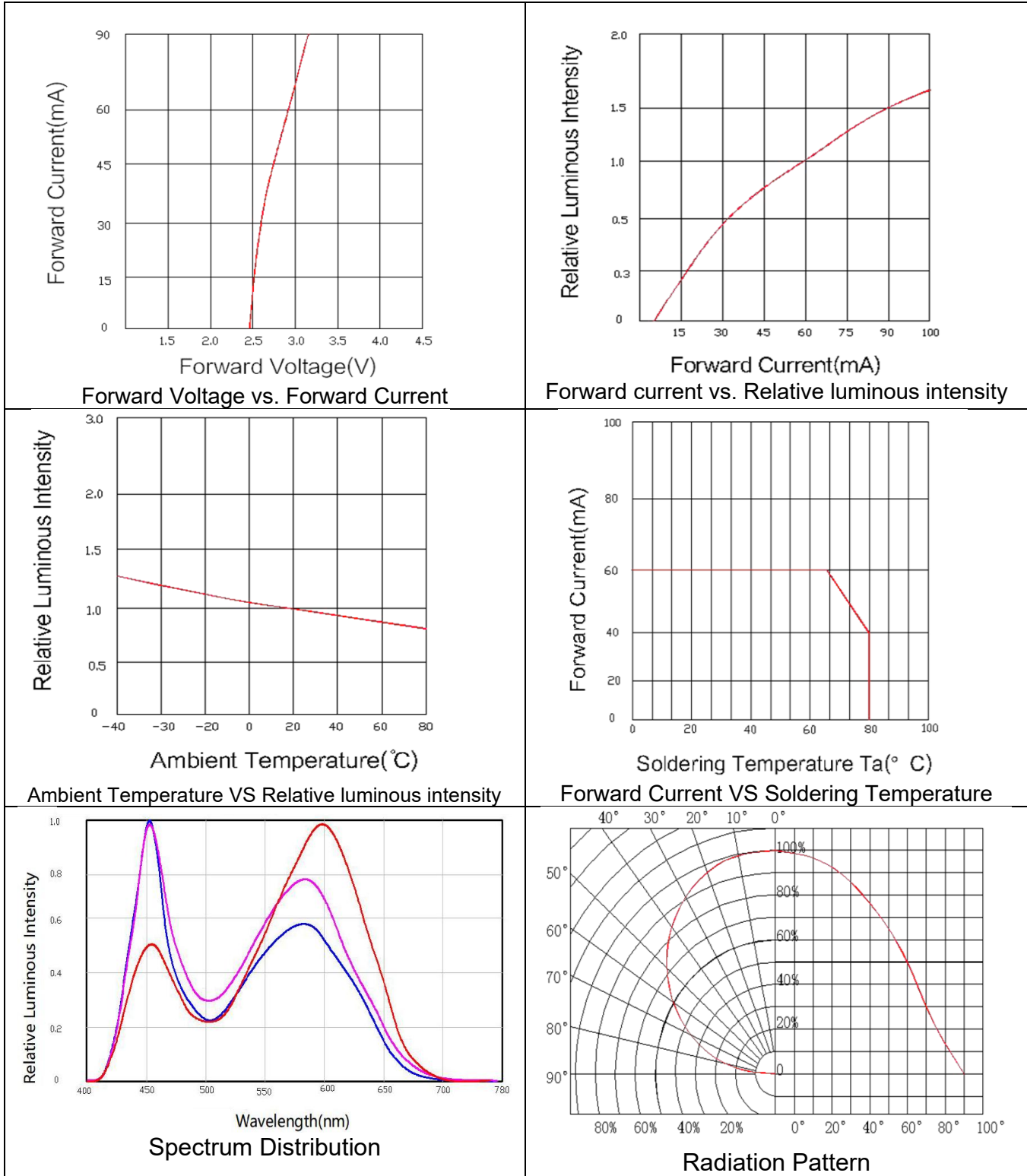

■ Reliability test:

No	Item	Condition	Time/Cycle	Sample size
1	Steady State Operating Life of Room Temperature	25°C Operating	1000 Hrs	20 pcs
2	Steady State Operating Life of Low Temperature -40°C	-40°C Operating	1000 Hrs	20 pcs
3	Steady State Operating Life of Low Temperature 60°C	60°C Operating	1000 Hrs	20 pcs
4	Steady State Operating Life of Low Temperature 85°C	85°C Operating	1000 Hrs	20 pcs
5	Low temperature storage -40°C	-40°C Storage	1000 Hrs	20 pcs
6	High temperature storage 100°C	100°C Storage	1000 Hrs	20 pcs
7	Steady State Operating Life of High Humidity Heat 60°C 90%	60°C/90% Operating	1000 Hrs	20 pcs
8	Steady State Pulse Operating Life Condition	25°C 10Hz duty=1/10 Operating	200 Cycle	20 pcs
9	Resistance to soldering heat on PCB (JEDEC MSL3)	pre-store@60°C, 60%RH for 52hrs Tslid max.=260 10sec	3 Times	20 pcs
10	Heat Cycle Test (JEDEC MRC)	25°C~65°C~-10°C, 90%RH, 24hr/1cycle	10 Cycle	20 pcs
11	Thermal shock	-40°C/ 20minr~ 5minr~100°C/20min	300 Cycle	20 pcs

■ Judgment Criteria:

Item	Symbol	Test Condition	Judgment Criteria
Forward Voltage	Vf	60 mA	$\Delta Vf < 10\%$
Luminous Flux	Iv	60 mA	$\Delta Iv < 30\%$



Solder Profile:

-The recommended reflow soldering profile is as follows (temperatures indicated are as measured on the surface of the LED resin):

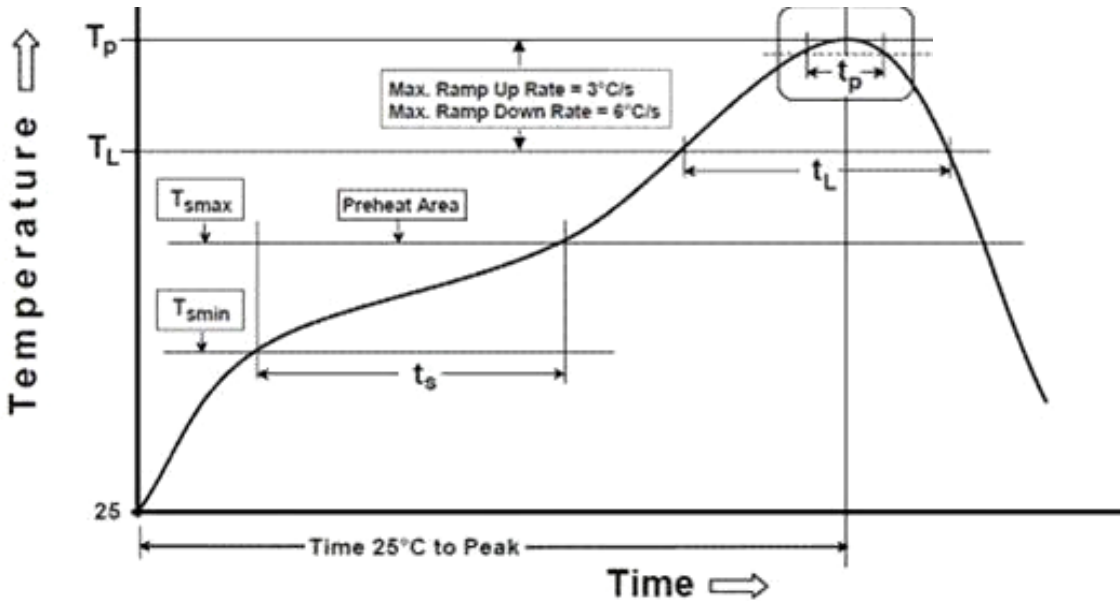

Profile Feature	Sn-Pb Eutectic Assembly	Pb-Free Assembly
Temperature Min(T_{smin})	100°C	150°C
Temperature Max(T_{smax})	150°C	200°C
Time(t_a) from (T_{smin} to T_{smax})	60-120 seconds	60-120 seconds
Ramp-up rate(T_L to T_p)	3°C/second max.	3°C/second max.
Liquidous Temperature(T_L)	183°C	217°C
Time(t_L) maintained above T_L	60-150 seconds	60-150 seconds
Peak package body temperature(T_p)	235°C	260°C
Time within 5°C of Actual Peak temperature (t_p)	20seconds*	30 seconds*
Ramp-down rate(T_p to T_L)	6°C/second max.	6°C/second max.
Time 25°C to peak temperature	6 minutes max.	8 minutes max.
* Tolerance for peak profile temperature (T_p) is defined as a supplier minimum and a user maximum.		

Note: Number of reflow process shall be less than 1 times



■ Notes:

ESD COUNTERMEASURE

Static electricity and high volt can damage led , The production whose Die material is InGaN must strictly required to prevent ESD , Must put on static glove and static fillet , Soldering tool and the cover of device must connect the ground , soldering condition follows the related stating of production specification manual ◦

PROTECTING COUNTERMEASURE WHEN OVER CURRENT

Need add the protecting resistor in circuit in order to avoid damaging led due to big current and voltage fluctuation ◦

LED INSTALLATION

(A). Pay attention to the led polarity and avoid installation wrong ◦ Led can't be close to euthermic component, work condition should tally with it's specification ◦

(B). Don't install the LED under the condition of the led pin deformation ◦

(C). The led bracket don't load any pressure when installing the led into PCB or fitting hole ◦

(D). Must avoid any strike and force on led before the soldering temperature return to room temperature.

STORAGE TIME

(A). Led can be stored for a year under the condition: the temperature of 5°C ~ 35°C and humidity of RH60%. These production must be re-inspected and tested before use if their storage time exceed a year.

(B). If led is exposed in air for a week under the condition: the temperature of 5°C ~ 35°C · humidity of RH60%. must place the led in the ambience of 65°C±5°C for 24 hours and use it in 15 days for best.

CLEANING

Be careful of some chemical results in the led colloid fades and damage when using chemical clean the led such as chloroethylene, acetone etc ◦ can use ethanol to wash or soak led but the time don't exceed 3 minutes.

KINKED

The kinked tooling scrape easliy the pin of led, where the led bracket is rusting easliy, especisal expose it in Moist air. To decrease the led bracket rust, advise using platse tin led bracket



Taping & Packing:

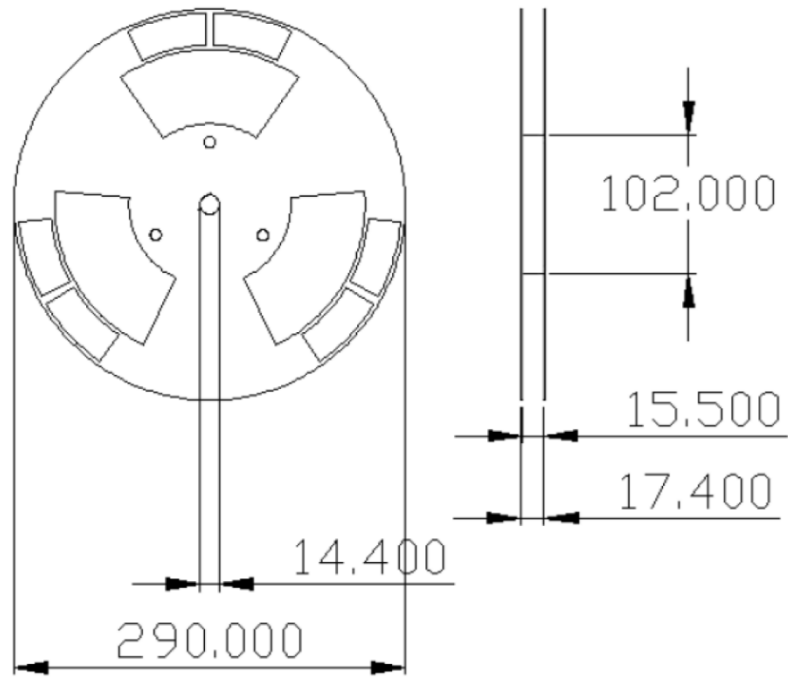
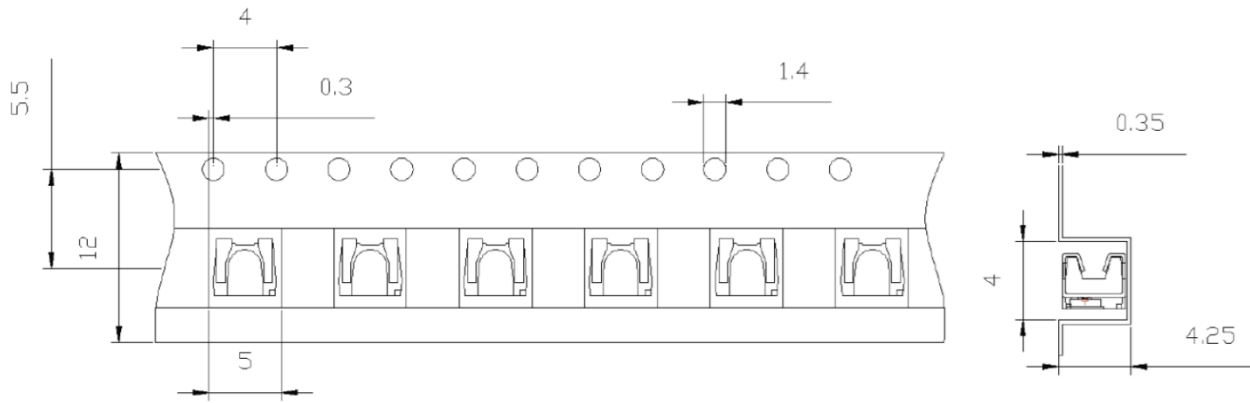

Unit : mm



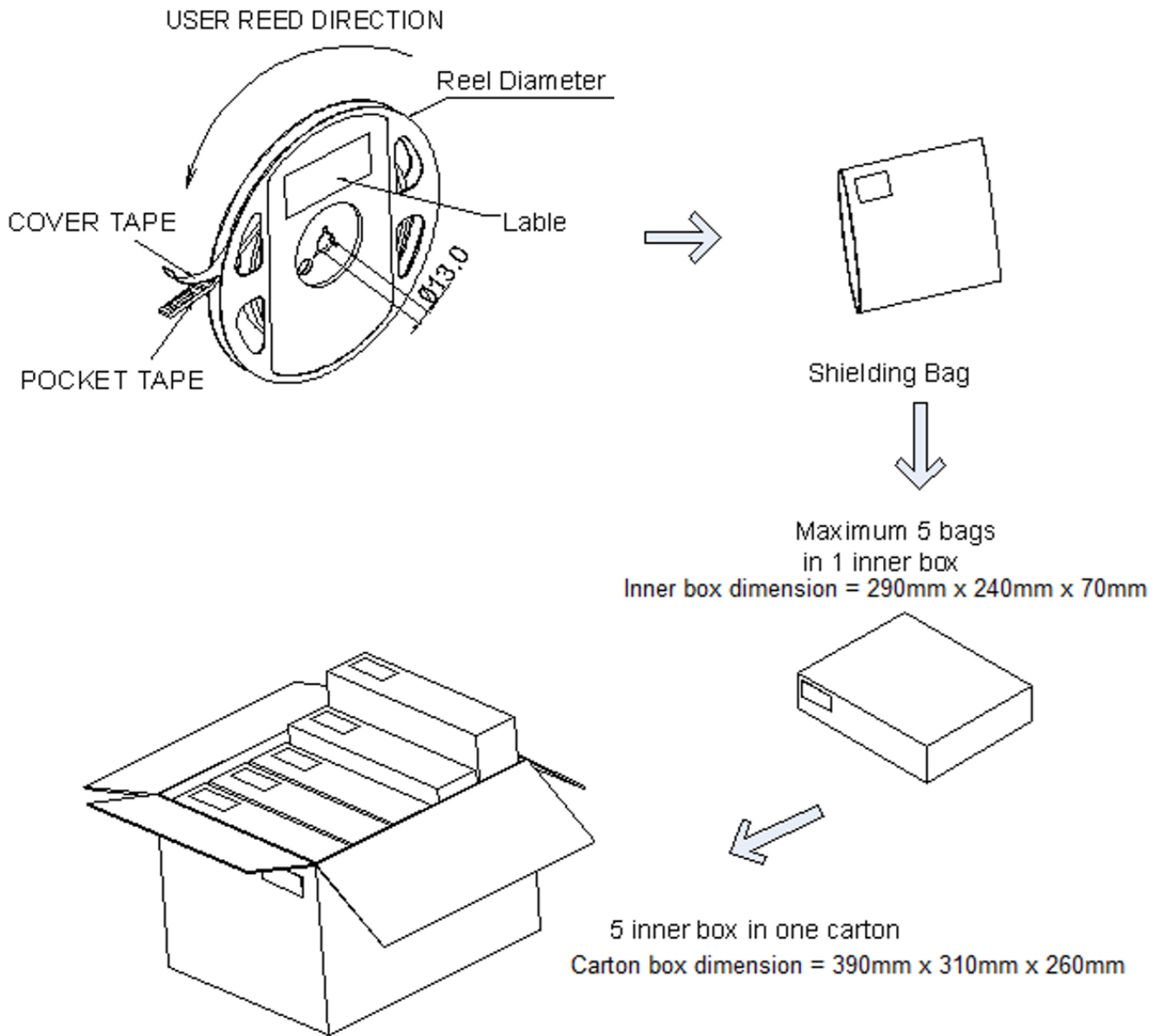

Labeling

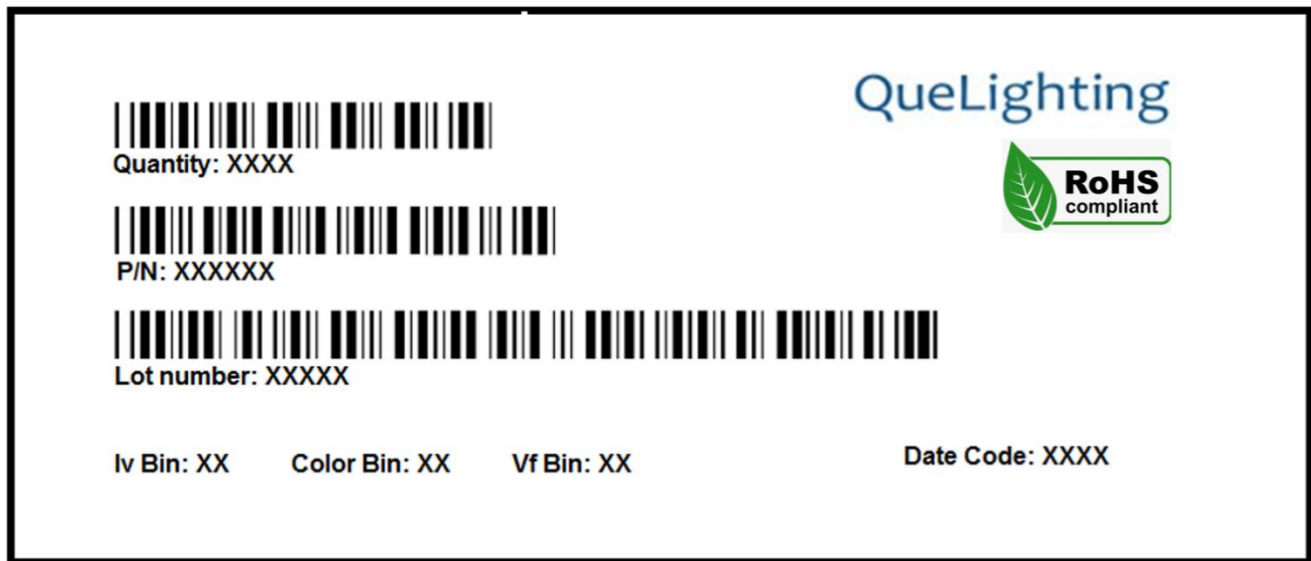

Ordering Information:

Part #	Multiple Quantities	Quantity per Reel
QLSP30WXK		1500 pcs



Revision History:

Revision Date:	Changes:	Version #:
08-01-2023	Initial release	1.0
1-15-2026	changed the quantity per reel to 1500pcs and added the Zener diode in package	1.1

