



QLSP05WXK-255
2835S



■ Product Outline:

This high output reflector type 2835S LEDs are available in warm white / neutral white / pure white / and cold white to suit customer's application. These 0.2W LEDs are equipped with heat sink to enhance operating performance. With special binning technology, these LEDs are ideal for architecture lighting and special lighting needs.

■ Features:

- High brightness output @ 60mA
- Max. current @ 100mA
- Package Dimension = 3.5mmX2.8mmX0.68mm
- CRI = 80 and above
- Available in white color
- ANSI binning
- RoHS compliant
- Custom Bin available upon special request

■ Application:

- Architecture Lighting
- Tube Lighting
- Interior Lighting
- General Lighting

Compliance and Certification:



■ **Mechanical Property:**
(Dimension)

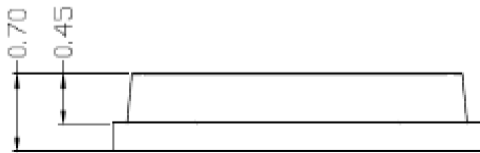
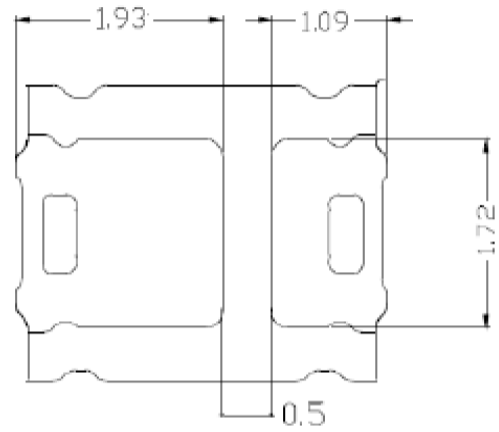
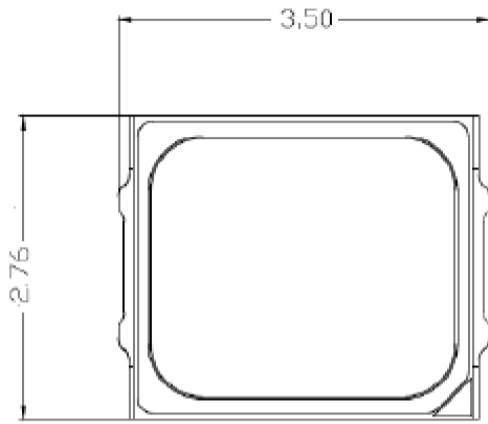

Unit: mm

Recommended Solder footprint:

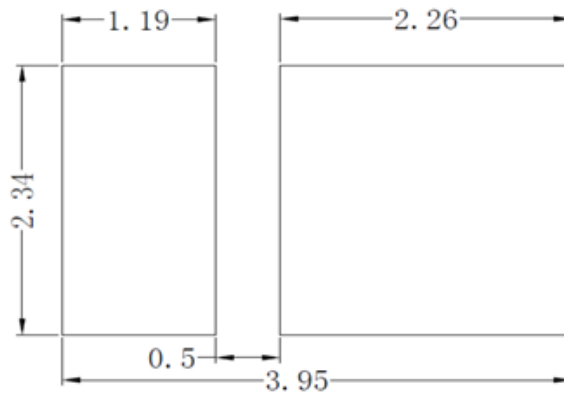

■ Product Selection with Ta=25°C, Test current 60mA

Product	Color	I _f (mA)	V _f (V)		CCT	CRI	Luminous Flux(lm)*		Typical Efficacy (lm/W)
			Typ.	max			Min	typ.	
QLSP05WW1K	Warm White	60	2.9	3.2	2700	80		27	155
QLSP05WW2K	Warm White	60	2.9	3.2	3000	80		28	161
QLSP05WNBK	Neutral White	60	2.9	3.2	4000	80		28	161
QLSP05WPK	Pure White	60	2.9	3.2	5000	80		29	167
QLSP05WC1K	Cold White	60	2.9	3.2	5700	80		29	167
QLSP05WC2K	Cold White	60	2.9	3.2	6500	80		29	167

*Tolerance = +/- 10%

■ Electrical / Optical Characteristic

Parameter	Symbol	Condition	Min.	Typ.	Max.	Unit
Forward voltage ⁽¹⁾	V _f	I _f =60mA	2.8	-	3.2	V
Color Rendering Index ⁽²⁾	R _a		80	-	-	-
View angle	θ		-	120	-	Deg
Thermal Resistance ⁽³⁾	R _{th}		-	25	-	°C/W

(1) The forward voltage tolerance is ± 0.1V

(2) The Color Rendering Index tolerance is ± 2



■ Absolute Maximum Rating

(T=25 °C)

Part #	P _d (mW)	I _F (mA)	I _{FP} (mA)*	V _R (V)	T _{OP} (°C)	T _{ST} (°C)	T _{SO L} (°C)**
QLS05WXK	350	100	200	5	-40 – 85	-40 - 105	260

*Duty 1/10 @ 10Khz

** IR Reflow for no more than 10 sec @ 250 °C

■ White Binning

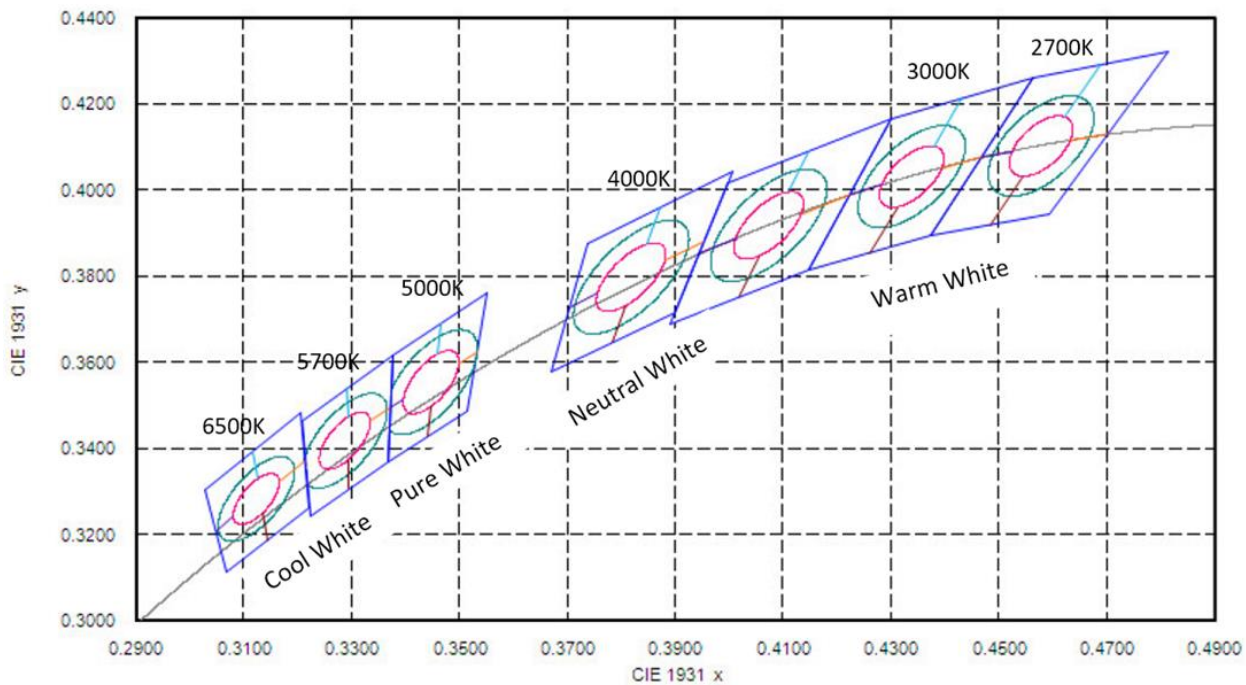

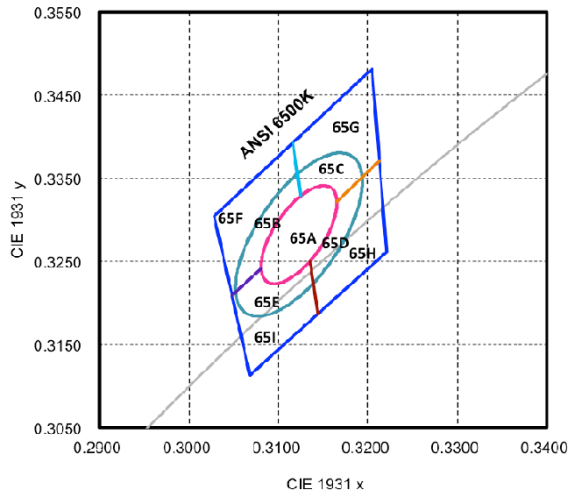
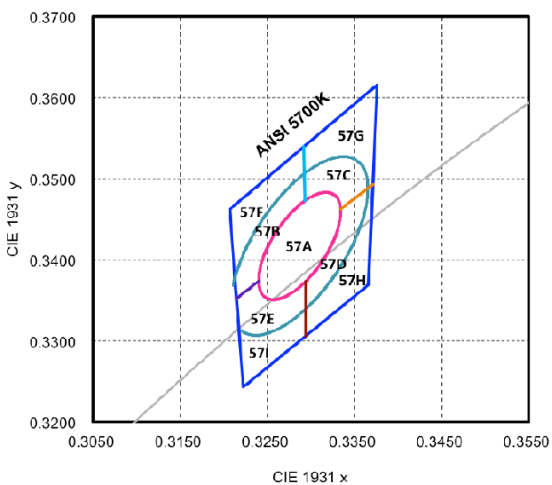
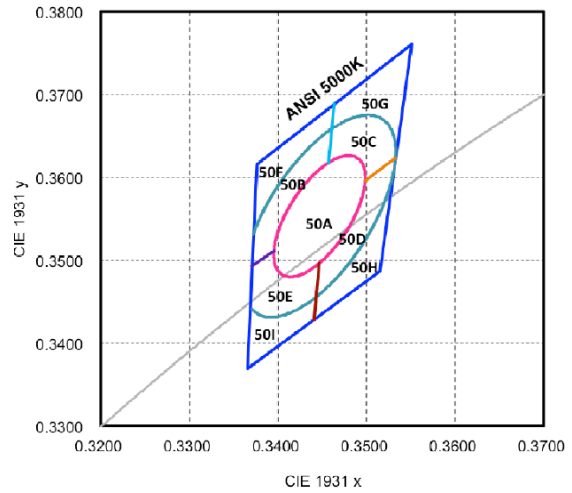
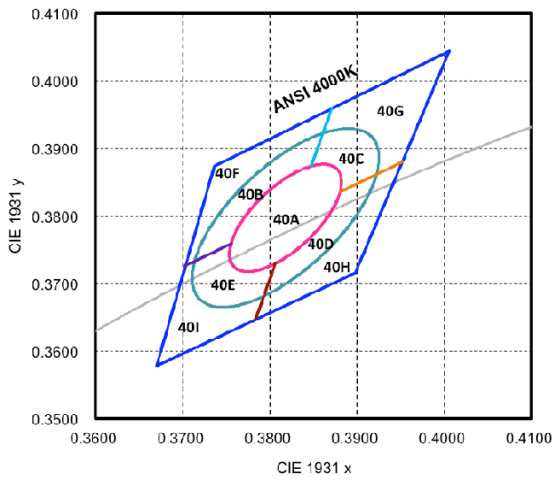
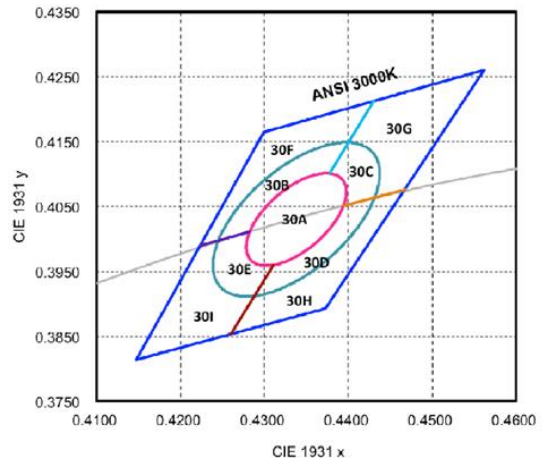
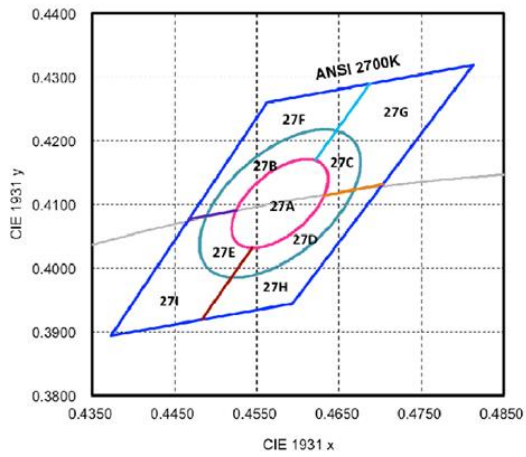

Note: (1). Correlated color temperature is derived from the CIE 1931 Chromaticity diagram
(2). Measurement tolerance is +/- 0.01



■ **Luminous Flux Bin:**

Im rank (Im) @ 60mA			
Code name	Low	High	Unit
QK	22.5	25	lm
QL	25	28	
QM	28	31.5	

The luminous flux tolerance is $\pm 10\%$

■ **Forward Voltage (VF) Bin:**

VF rank @ 150mA			
Code name	Low	High	Unit
Z	2.8	2.9	V
1	2.9	3	
2	3	3.1	
3	3.1	3.2	

The forward voltage tolerance is $\pm 0.1V$



Characteristic Curves

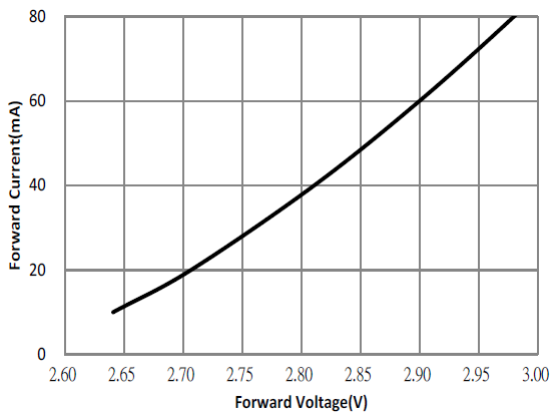

Forward Voltage vs. Forward Current

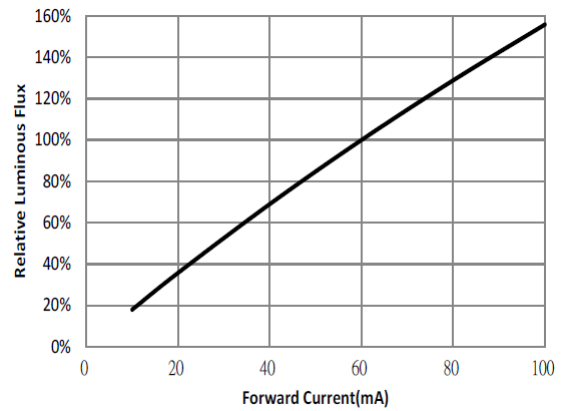

Forward current vs. Relative luminous intensity

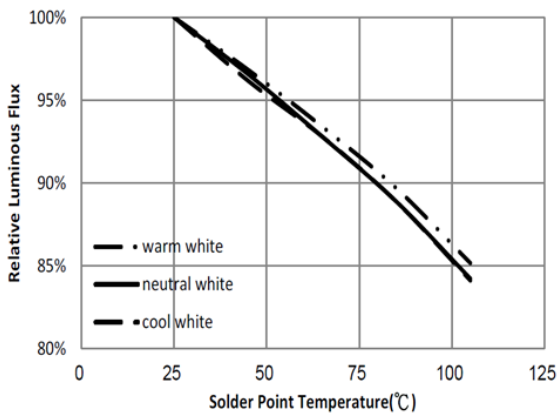

Forward Current VS Soldering Temperature

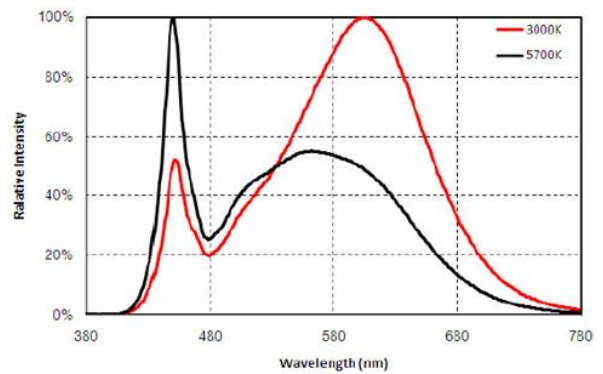

Spectrum Distribution



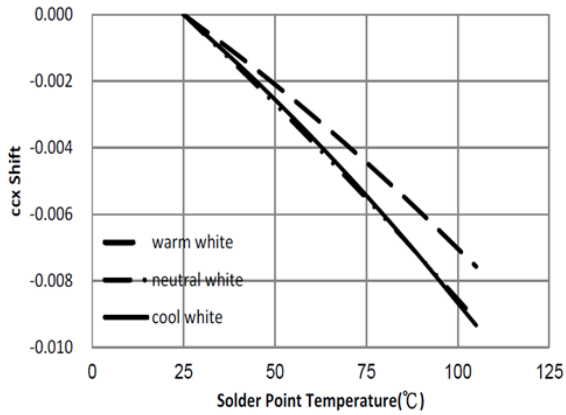

Typical ccx Shift vs. Solder Point Temperature

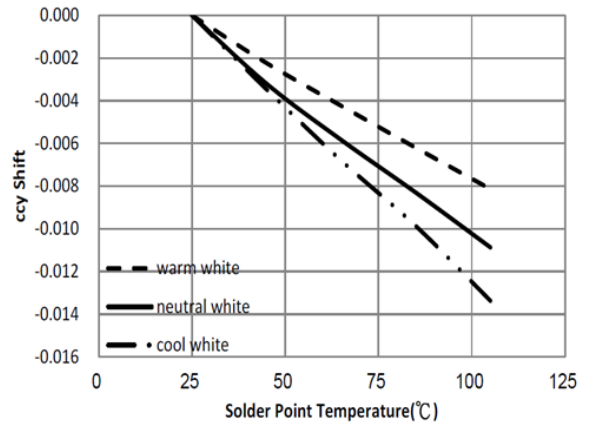

Typical ccy Shift vs. Solder Point Temperature

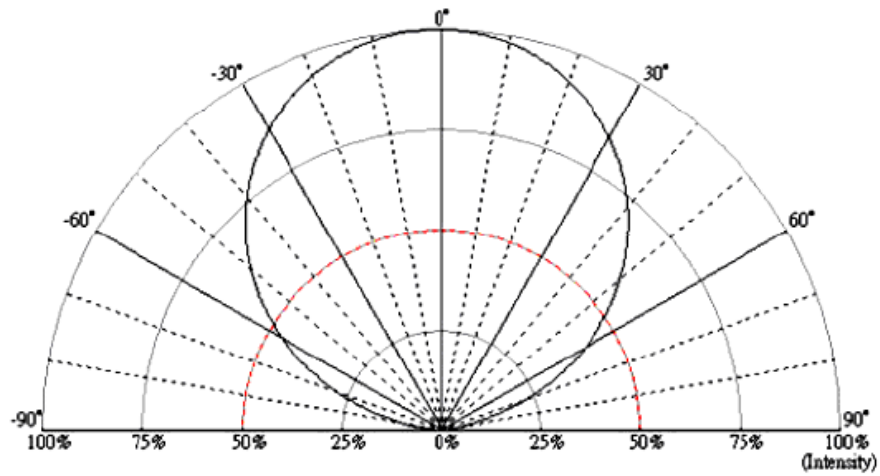

Radiation Pattern



■ Reliability test:

No	Item	Condition	Time/Cycle	Sample size
1	Steady State Operating Life of Room Temperature	25°C Operating	1000 Hrs	20 pcs
2	Steady State Operating Life of Low Temperature -40°C	-40°C Operating	1000 Hrs	20 pcs
3	Steady State Operating Life of Low Temperature 60°C	60°C Operating	1000 Hrs	20 pcs
4	Steady State Operating Life of Low Temperature 85°C	85°C Operating	1000 Hrs	20 pcs
5	Low temperature storage -40°C	-40°C Storage	1000 Hrs	20 pcs
6	High temperature storage 100°C	100°C Storage	1000 Hrs	20 pcs
7	Steady State Operating Life of High Humidity Heat 60°C/90%	60°C/90% Operating	1000 Hrs	20 pcs
8	Steady State Pulse Operating Life Condition	25°C/10Hz duty=1/10 Operating	200 Cycle	20 pcs
9	Resistance to soldering heat on PCB (JEDEC MSL3)	pre-store@60°C, 60%RH for 52hrs Tslid max.=260 10sec	3 Times	20 pcs
10	Heat Cycle Test (JEDEC MRC)	25°C~65°C~-10°C, 90%RH, 24hr/1cycle	10 Cycle	20 pcs
11	Thermal shock	-40°C/ 20minr~ 5minr~100°C /20min	200 Cycle	20 pcs

■ Judgment Criteria:

Item	Symbol	Test Condition	Judgment Criteria
Forward Voltage	Vf	100 mA	$\Delta Vf < 10\%$
Luminous Flux	Iv	100 mA	$\Delta Iv < 30\%$



■ Solder Profile:

-The recommended reflow soldering profile is as follows (temperatures indicated are as measured on the surface of the LED resin):

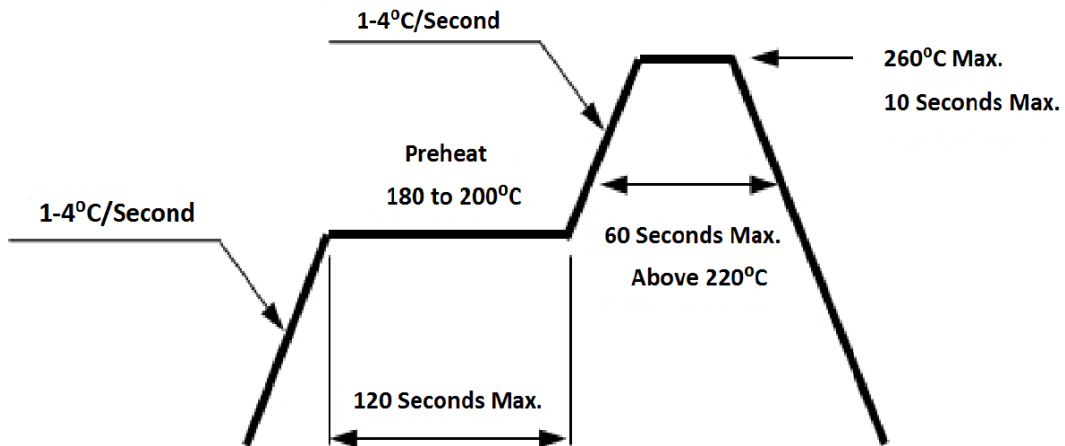

■ Taping & Packing

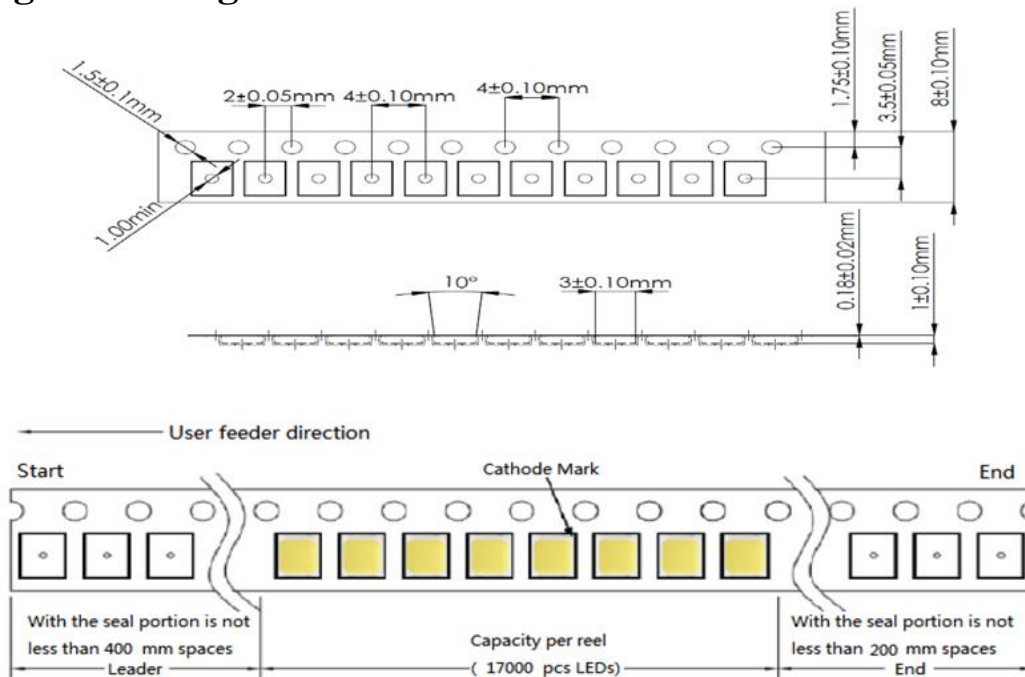



Unit : mm

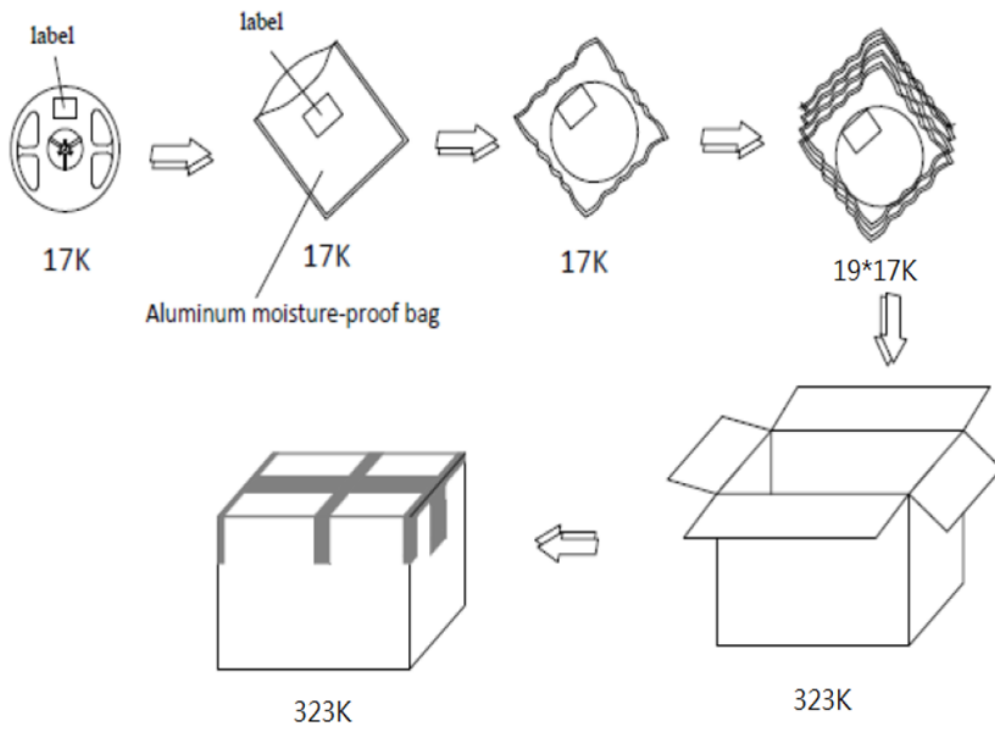
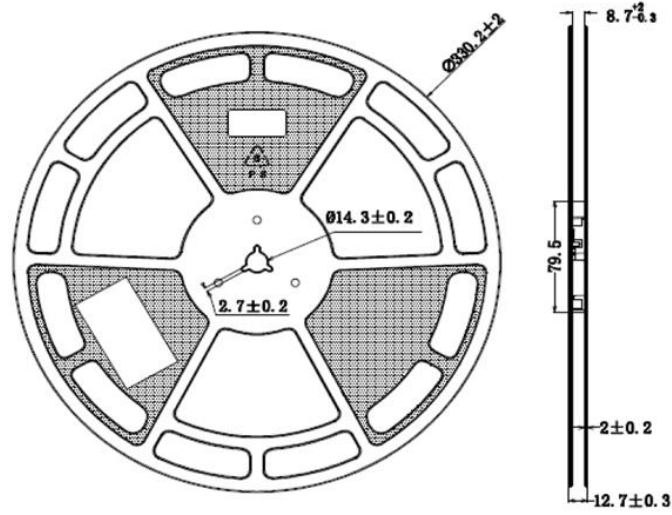





Labeling

Quantity: XXXX





QueLighting P/N: XXXXXX



Lot number: XXXXX

Iv Bin: XX

Color Bin: XX

Vf Bin: XX

Date Code: XXXX

Ordering Information:

Part #	Multiple Quantities	Quantity per Reel
QLSP05WXK-255		17000 pcs



Revision History:

Revision Date:	Changes:	Version #:
03-10-2020	Initial release	1.0

